

# GSP0511

## CAST IRON SUMP AND EFFLUENT PUMP



### FEATURES

- Reliable Mechanical switch coupled with solid float for dependable performance
- Cast Iron Motor Housing allowing for optimal heat dissipation
- Approved for Residential use (CSA/CUS Listed)
- Premium Mechanical Seal design provides superior protection against sand and abrasive damage (Silicon Carbide/Carbon/BUNA)
- Engineered motor designed for peak hydraulic performance without overloading
- Cast Iron Suction Strainer encompasses entire base - designed to reduce debris entry
- Corrosion resistant hardware for lifetime use
- 2 year warranty

### PRODUCT SPECIFICATIONS

Model	Part No.	HP	Volts	Amps	Minimum Circuit Breaker	Phase	Float Switch Style	Cord Length	Discharge Connection	Minimum On Level	Minimum off Level	Minimum Basin Diameter	Max. Solids Size	Shipping Weight
GSP	GSP0511	1/2	115	8	15A	1	Vertical	15'	1 1/2"	8 1/2"	3"	1'	1/2"	38 lbs
GSP	GSP0511M	1/2	115	8	15A	1	Not Supplied	15'	1 1/2"	-	-	1'	1/2"	37 lbs

### REPAIR PARTS

Part Description	Part No.	Part
GSP-SWITCH	9K701	Switch Assembly with Gasket and Hardware

## GSP05 PERFORMANCE CURVE

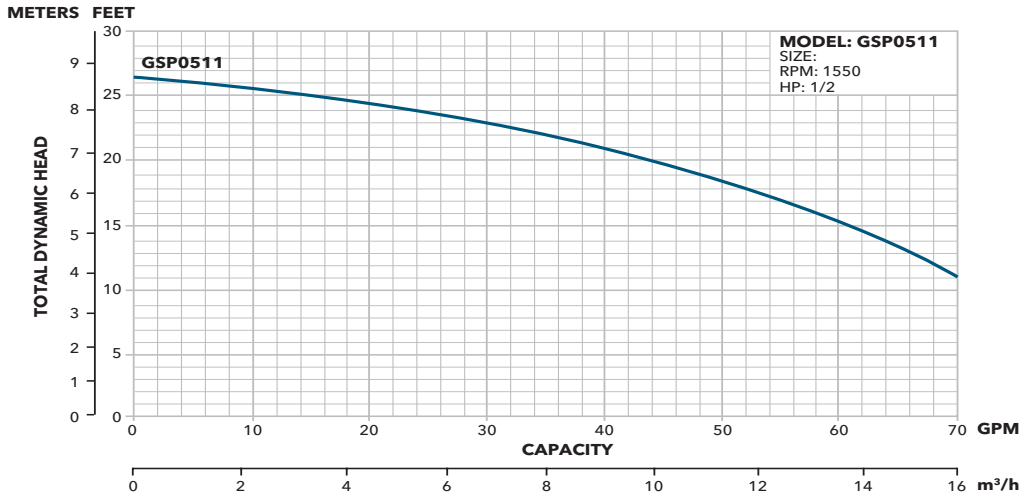

## PERFORMANCE RATINGS

Total Head (feet of water)	GPM	GPH
10	71	4260
15	56	3360
20	38	2280
23	20	1200

## COMPONENTS

Item No.	Description
1	Float Bracket
2	Float Rod
3	Float
4	Base
5	Seal Housing
6	Plug
7	Motor Dome
8	Mechanical Switch Housing
9	Handle

## DIMENSIONS

	A	B	C	D	E
GSP0511	12"	10.6"	5"	7.4"	10.6"
GSP0511M	12"	9.4"	5"	7.4"	9.4"

## MATERIALS OF CONSTRUCTION

Part Name	Material
Impeller	Thermoplastic (Nylon)
Casing	Cast Iron Motor Housing
Base/Volute/Strainer	Cast Iron
Motor Adapter	Cast Iron
Mechanical Seal	Silicon Carbide/Carbon/BUNA
Cord and Current	18 AWG, SJTW
Mechanical Switch	cURus listed, 15A, 125V
Fasteners	Stainless Steel
Handle	Stainless Steel
Float Bracket	Stainless Steel

## AGENCY LISTINGS

 Tested to UL778 CAN 22.2 by  
 CSA International (Canadian Standards Association)

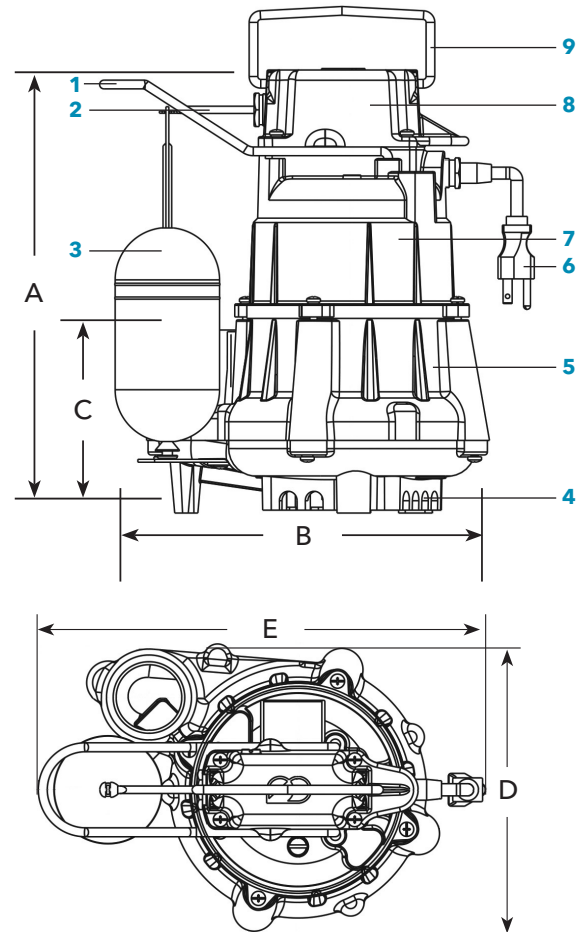

**xylem**  
 Let's Solve Water

Xylem Inc.  
 2881 East Bayard Street Ext., Suite A  
 Seneca Falls, NY 13148  
 Phone: (866) 325-4210 • Fax: (888) 322-5877  
[www.xylem.com/goulds](http://www.xylem.com/goulds)

Goulds is a registered trademark of Goulds Pumps, Inc. and is used under license.  
 © 2019 Xylem Inc. GSP05SALES R3 June 2019